

GBP910C

HYDRAULIC POWERUNIT

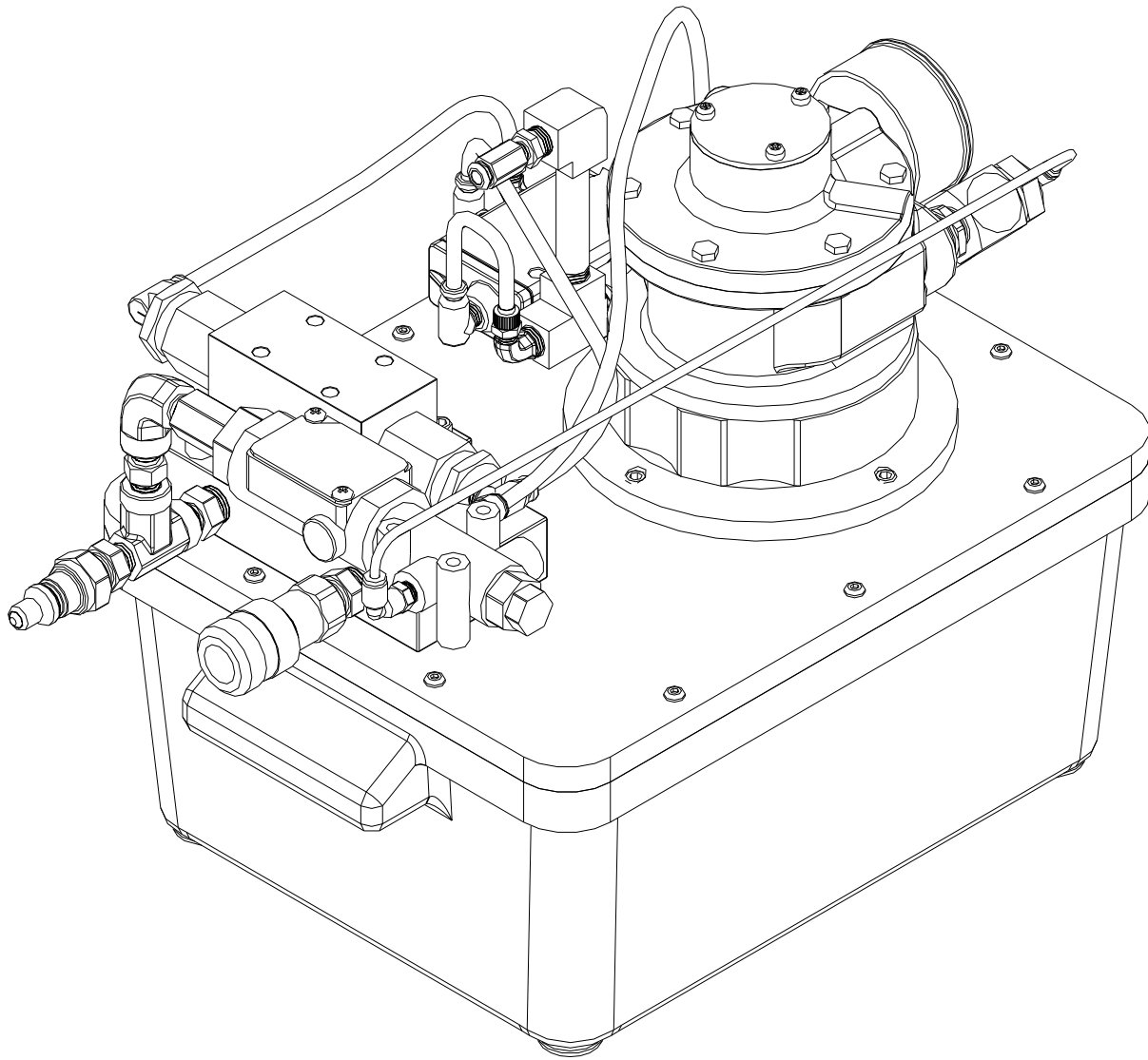

GAGE BILT
MADE IN U.S.A.

GAGE BILT PRODUCTS CORP.

14500 Barber Drive (586) 771-7664
Warren, Mi 48088 (586) 771-2665 Fax
e-mail: solutions@gagebilt.com / www.gagebilt.com

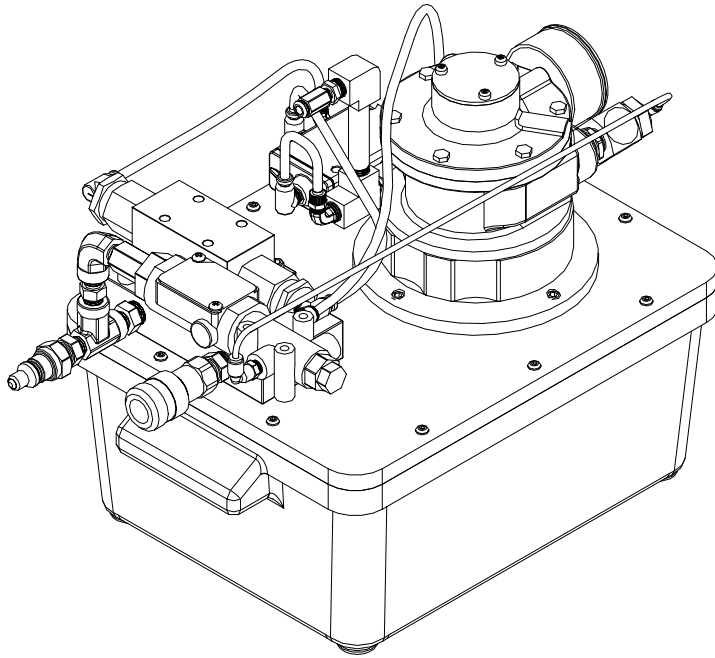

WARNING:
 Please read this manual before servicing or using tool. Comply with WARNINGS and CAUTIONS to prevent personal injury or damage to tool.

WARNING:
 When operating installation equipment always wear approved eye protection .



TABLE 1

NOTE:

Shipped with Pull pressure at 10,000 psi (68,950 kPa) & Return pressure at 6,000 psi (41,370 kPa) for GBP7500AA. When attaching GBP585A set Pull pressure to 5,400-5,700 psi (37,350-39,300 kPa) & Return pressure 2,200-2,400 psi (15,200-16,500 kPa).

Width.....	13.0 inches.....	330mm
Length.....	20.5 inches.....	520mm
Height.....	14.0 inches.....	356mm
Weight (without hyd. fluid).....	74 pounds.....	33.6kg
Remote Control.....	Solenoid operated Directional Valve	
Motor.....	3,450 RPM, 1-1/2 HP	
Pump.....	2 - stage, Gear-Piston Type, 50 cu.in./min. @ 5000 psi	
Output Pressure.....	Adjustable to 10,000 psi	
Reservoir Capacity.....	2 gal.....	006m
Operating Temperature (Ambient-min.)	0° F.....	-18° C
(Hydraulic Fluid-max.)	140° F.....	65° C

Hydraulic Fluid:

Automatic Transmission Fluid (Dextron III or equivalent - SUS 185 100° F and SUS 50 210° F)

DESCRIPTION:

The GBP910C Powerunit is a portable, air operated hydraulic power source designed to operate GBP hydraulic installation equipment. It is also compatible with HUCK® hydraulic installation equipment.

The GBP910C Powerunit operates on 90 - 120 psi., using 62 cfm @ 100 psi.

Page 9 & 10 shows construction features of the GBP910C Powerunit and identifies main components. Hydraulic pressure is developed by a two-stage, gear piston hydraulic pump driven by a 1-1/2 hp motor. Pump output is directed to either the PULL or RETURN pressure ports of the installation equipment by a four-way directional valve. The directional valve is controlled from the installation equipment by an air trigger.

For the protection of the equipment and operator, an internal relief valve is pre-set at the factory. An external relief valve controls the PULL pressure. A pressure switch controls the RETURN pressure and automatically turns off the GBP910C Powerunit. When the trigger is released, the installation cycle is finished.

As shipped by the factory, the external relief valve Pull pressure is set at 10,000 psi (68,950 kPa) & Return pressure at 6,000 psi (41,370 kPa) for GBP7500AA. When attaching GBP585A set Pull pressure to 5,400-5,700 psi (37,350-39,300 kPa) & Return pressure 2,200-2,400 psi (15,200-16,500 kPa).

CAUTION: SEVERE PERSONAL INJURY OR DAMAGE TO THE SYSTEM AND PERIPHERAL EQUIPMENT MAY OCCUR IF PRESSURES ARE NOT PROPERLY CALIBRATED. CONSULT YOUR INSTALLATION TOOL MANUAL FOR RECOMMENDED PRESSURES, AND ON PAGE 5 & 6 OF THIS MANUAL FOR DIRECTIONS.

The reservoir is equipped with two handles to ease the transferring of the GBP910C Powerunit to various sites. The GBP910C Powerunit weighs approximately 89 pounds (40.4 Kg) when filled with hydraulic fluid.

Hydraulic quick disconnect couplers are supplied for connecting the tool hoses from the installation equipment.

WARNING:

PROPER PULL AND RETURN PRESSURES ARE IMPORTANT FOR PROPER FUNCTION OF INSTALLATION TOOLS. SEVERE PERSONAL INJURY OR DAMAGE TO EQUIPMENT MAY OCCUR WITHOUT CORRECT PRESSURES. GAUGE SET-UP, P/N 942280, IS AVAILABLE FOR CHECKING THESE PRESSURES. SET PRESSURES PER INSTRUCTIONS FURNISHED WITH APPLICABLE HYDRAULIC INSTALLATION TOOL INSTRUCTION MANUAL. SEE "SETTING PRESSURES".

WARNING:

GBP RECOMMENDS THAT ONLY GBP POWERUNITS BE USED FOR GBP INSTALLATION EQUIPMENT. HYDRAULIC POWERUNITS THAT DELIVER HIGH PRESSURE FOR BOTH PULL AND RETURN ARE NOT EQUIPPED WITH RELIEF VALVES AND ARE SPECIFICALLY NOT RECOMMENDED, AND MAY BE DANGEROUS.

CAUTION:

KEEP DIRT AND OTHER FOREIGN MATTER OUT OF HYDRAULIC SYSTEMS OF TOOLS, HOSES, COUPLERS AND POWERUNIT . DO NOT LET HOSE FITTINGS AND COUPLERS CONTACT A DIRTY FLOOR OR UNCLEAN WORKING SURFACE. FOREIGN MATTER IN HYDRAULIC FLUID MAY CAUSE TOOL AND AND THE POWERUNITS VALVES TO MALFUNCTION.

INITIAL USE:

1. Filling the Reservoir.
 - A. Clean the area around the filler cap to remove all dust and grit. Any dirt or dust in the oil can damage the pump.
 - B. Set all pistons to the return position.
 - C. Remove the filler cap and fill with hydraulic oil to within 1/2" from the top of the filler hole. Replace filler breather cap.
 - D. Hydraulic fluid is not shipped with the GBP910C Powerunit and is not available from GBP Corp. Fire-resistant hydraulic fluid must be used to conform with the Occupational Safety and Health Administration (OSHA) regulation 1926.302, paragraph (d) "the fluid used in hydraulic powered tools shall be fire-resistant fluids approved under Schedule 30 of the U.S. Bureau of Mines, Department of the Interior, and shall retain its operating characteristics at the most extreme temperatures to which it will be exposed." For ambient temperatures between 0 F and 130° F, a fluid with the viscosity range of 300 SUS at 100° F and 50 SUS at 210° F is recommended. Seals compatible with phosphate ester hydraulic fluids are furnished with the GBP910C Powerunit.
 - E. Connect the PULL pressure hose to the output marked PULL. Connect the RETURN to the output marked RETURN.
 - F. Cycle the pump (with tool attached) several times. Re-check the oil level in the pump reservoir with the tool in the relaxed (return) position.
 - G. Check for leaks.
2. The GBP910C powerunit and installation tool are ready for attaching the applicable nose assembly.

OPERATION:

The unit should be connected to an air source, and actuated with the air trigger on the tool. This will start the motor and it will run until the return line pressure switch is satisfied, which will then shut the motor off. Now you are ready to install rivets. Load rivet and collar and place in work piece. The circuit is activated by pulling on gun trigger. It puts power to the motor and the unit builds pressure to install the rivet. When the trigger is released the motor will continue to run until line pressure is satisfied, which then shuts the motor off until next cycle.

CAUTION:

ENSURE POWERUNIT DOES NOT EXCEED RECOMMENDED INSTALLATION TOOL PRESSURES.

PREPARATION:

To avoid poor performance and down time, keep foreign material from getting into the hydraulic system. Observe the following points:

1. Check tool manual for recommended pressures.
2. Wipe off couplers before connecting them.
3. Do not let hose fittings or couplers lie on the ground or dirty floor.
4. Clean area around filler cap before filling the reservoir with hydraulic fluid.
5. Use a clean funnel with filter.
6. Drain and clean reservoir and fill with clean fluid on a regular basis.
- 7.

REGULAR USE:

Before the GBP910C Powerunit is used:

1. Check hydraulic fluid level in reservoir and if necessary add fluid. NOTE! Unit is shipped without oil.
2. Inspect hoses for damage or wear and if necessary replace.
3. Check the entire GBP910C Powerunit for leaks and if necessary repair.

MAINTENANCE:

WARNING:

MAKE SURE AIR IS DISCONNECTED BEFORE SERVICING ANY COMPONENTS.

Scheduled inspections to detect and correct minor problems are part of an effective preventive maintenance program.

1. Inspect hydraulic fittings to make sure they are secure.
2. Inspect hoses for signs of damage. Replace hoses if necessary.
3. Inspect during operation to detect any leakage, abnormal heating or vibration.
4. Inspect hydraulic fluid on a regular basis. Clean reservoir and replace fluid if contamination is detected.
5. Keep exterior surfaces clean.

The GBP910C Powerunit should be checked, as required by the installation tool manual, at first time start-up, when troubleshooting and after overhauling directional valve or pump. For assisting in this procedure use Pressure Checking Gauge Set-Up 942280.

TO CHECK PULL PRESSURE

1. Disconnect tool from GBP910C power unit
2. Connect valve #1 of pressure gage to pull side of GBP910C power unit
3. Open valve #1 (counter clockwise) and close valve #2 (clockwise)
4. Plug the air trigger from the installation tool into power unit.
5. Cycle tool to start the motor and directing hydraulic fluid to pull side of power unit.
And read gage pressure.

CAUTION: THE GBP910C POWERUNIT IS DESIGNED FOR HIGH PRESSURES FOR ONLY A SHORT PERIOD. COMPLETE THIS CHECK AS QUICKLY AS POSSIBLE.

TO CHECK RETURN PRESSURE

1. Disconnect tool from GBP910C power unit
2. Connect valve #2 of pressure gage to return side of GBP910C power unit
3. Open valve #2 (counter clockwise) and close valve #1 (clockwise)
4. Plug the air trigger from the installation tool into power unit.
5. Cycle tool to start the motor, release trigger directing hydraulic fluid to return side of power unit and read gage pressure.

SETTING OR ADJUSTING OUTPUT PRESSURES

PULL Pressure Procedure: (See page 9 for adjusting screw location.)

1. Turn adjusting screw in to increase PULL pressure.
2. Turn adjusting screw out to decrease PULL pressure.

RETURN Pressure Procedure:

1. Loosen 2 screws on name plate on top of return pressure switch.
2. Swivel name plate to the side.
3. Use 2 pin punch's to loosen lock washer.
4. Tighten or loosen adjusting nut against spring to increase or decrease return pressure. Tightening or compressing spring will increase return pressure. Once pressure is set tighten lock nut against adjusting nut.

PRESSURE SETTING:

The Pressure Checking Gauge Set-Up, part number 942280 is used to check the pressure settings for PULL and RETURN pressures. Personnel servicing the GBP910C Powerunit should be given access to this gauge set-up.

Replacement couplers are available in a set, part number 585037, which includes one body (female) and one nipple (male).

Replacement o'ring for the body is part number 404438 and the back-up ring is part number 401102.

PARTS LIST - GAUGE SET-UP

Ref.	Part Number	Qty.	Description
1	403367	1	Hydraulic Gauge-10,000 psi
2	403912	1	Adapter
3	(1)	1	Coupler Nipple
4	403683	4	Hex Nipple
5	403368	2	Shut-Off Valve
6	403911	1	Tee
7	(1)	1	Coupler Body

(1) Available in sets as part number 585037

CHECKING OUTPUT PRESSURES

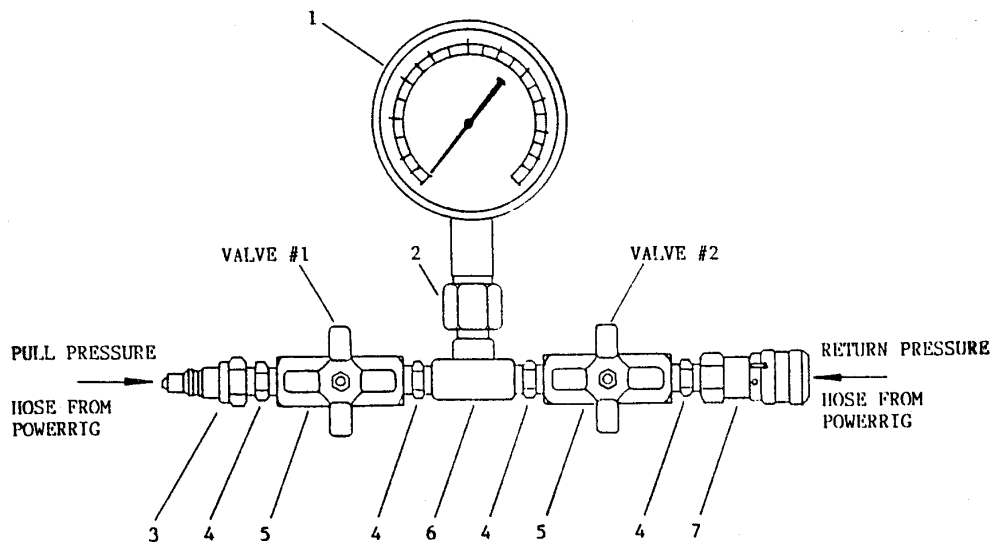

TROUBLESHOOTING:

Use the Troubleshooting Chart as an aid in locating problems and correcting them. Always check out the simplest possible cause of malfunction first. Eliminate each possible cause until the defective circuit or part is located. Substitute good parts for suspected bad parts.

TROUBLE SHOOTING CHART:

1. Tool will not reciprocate when motor is running.
 - A. Improperly coupled hoses.
 - B. Bind in tool or nose assembly.
 - C. Pump to motor coupling damaged.
 - D. Hydraulic fluid level is low or viscosity not proper.
 - E. Unloading valve in tool improperly installed or missing.
2. Fastener pintail fails to break off.
 - A. PULL pressure set too low.
 - B. Defective hose couplers.
 - C. Defective internal relief valve or set too low.
 - D. Overheated hydraulic fluid.
 - E. Hydraulic fluid level low or viscosity not proper.
 - F. Defective pump.
3. Tool will not return or push nose assembly off swaged fastener when switch is released.
 - A. RETURN pressure set too low.
4. When the installation cycle is complete, motor fails to shut off.
 - A. Pressure switch set too high.
 - B. Overheated hydraulic fluid.
 - C. Hydraulic fluid level low or viscosity not proper.
 - D. Defective pressure switch.
5. Pump making noise throughout operating cycle.
 - A. Pump is cavitating, the fluid viscosity is too heavy or the fluid level may be too low.
 - B. Filter is clogged or dirty.
6. Tool operates slow throughout entire cycle.
 - A. Pump is cavitating, the fluid viscosity is too heavy or the fluid level may be too low.
 - B. Filter is clogged or dirty.
 - C. Defective pump.

GBP910C Parts List

Ref. No.	Part Number	Description	Qty.
1	A-893	Reducer	1
2	910004	Pump	1
3	A-509	Elbow	4
4	910033	Solenoid	2
5	910034	Valve	1
6	910036	Air Line	1
7	A-553	Solenoid Stop Valve	1
8	910010	Muffler	1
9	910038	Hose	1
10	A-93	Brass Pipe Cross	1
11	A-816	Nipple	1
12	909104	Valve	1
13	910035	Tee Assembly	1
14	A-525	Nipple	1
15	A-90	Elbow	3
16	A-1078	Pressure Switch	1
17	A-507	Adapter	2
18	910020	Air Line	2
19	910041	Air Line	1
20	910037	Air Line	1
21	A-749	Elbow	1
22	A-96	Elbow	1
23	A-95	Hex Nipple	1
24	A-512	Tee	1
25	585037	Hydraulic Coupler Assembly	1
26	A-212	Adapter	1
27	403912	Hex Nipple	1
28	403683	Nipple	1
29	A-506	Tee	1
30	A-561	Elbow	1
31	942406	Quick Disconnect	1
32	A-912	Elbow	1
33	A-217	Fitting	1

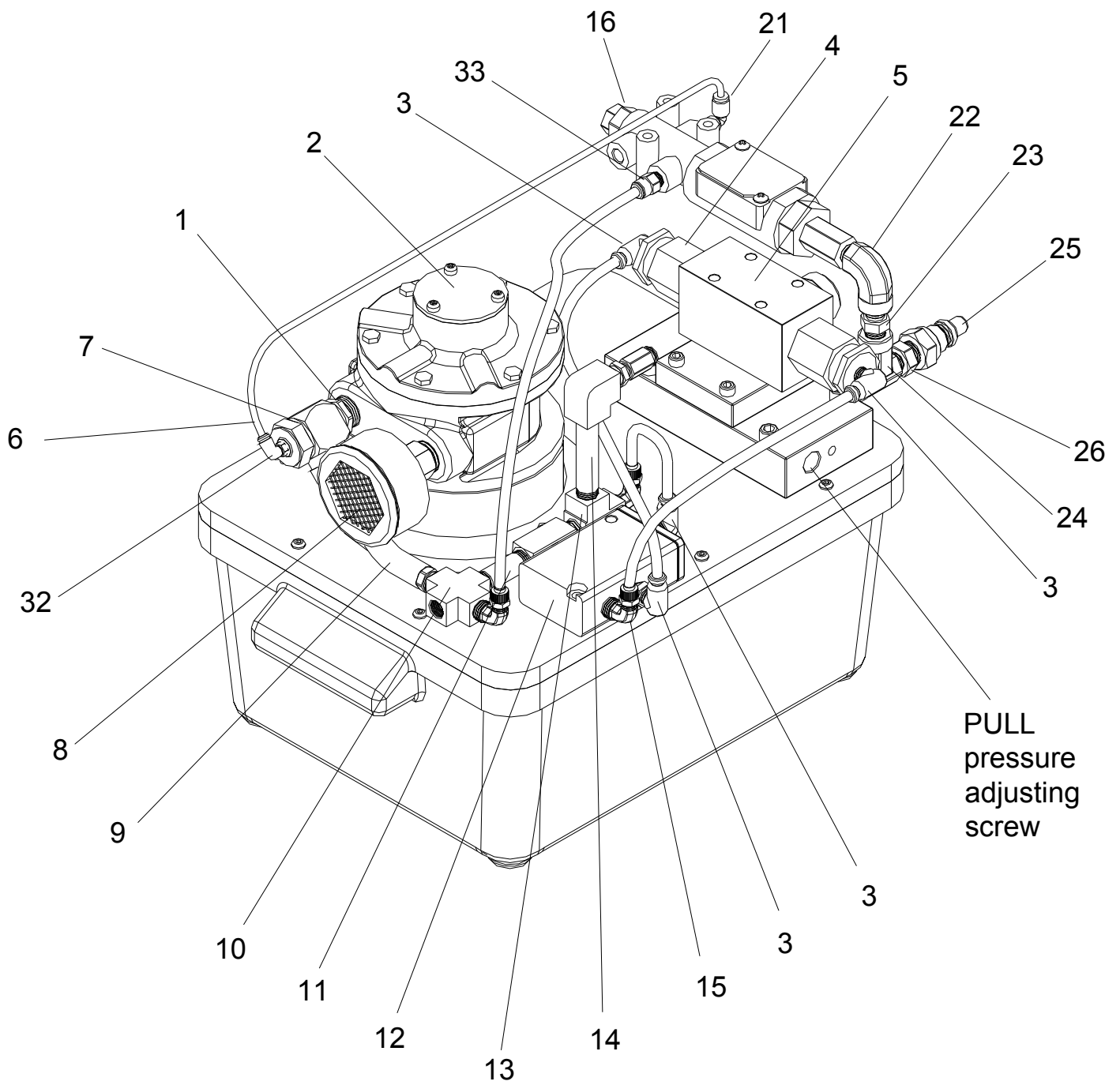

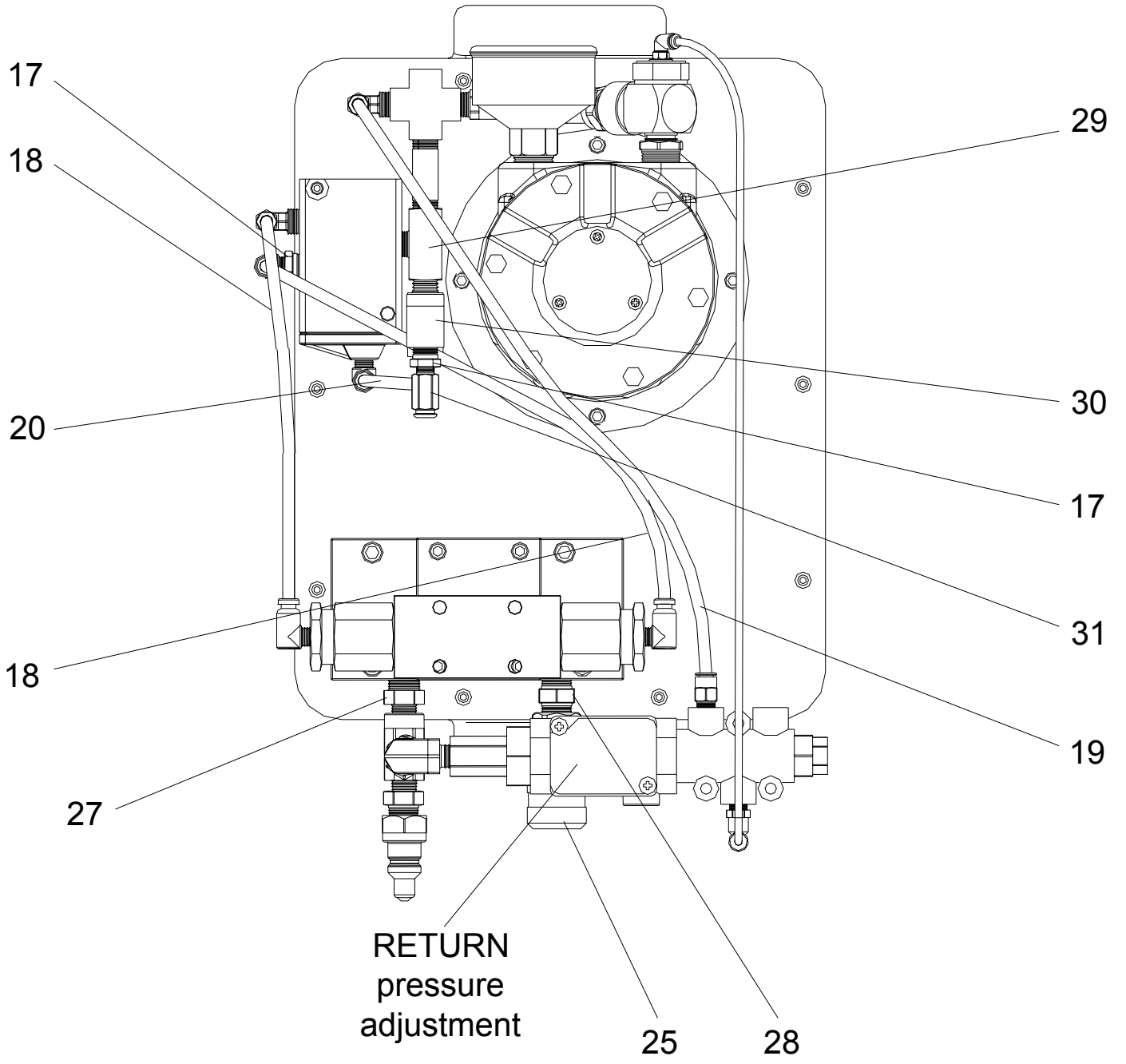

GBP910C Powerunit Kits

The GBP910C Powerunit is available in various kits to suit your particular need. The kits include the GBP910C Powerunit, control cord, hoses, hydraulic couplers and air connector for attaching installation equipment.

The GBP910C-12 Kit includes the GBP910C Powerunit and a 12-foot Hose Kit, part number 910701

The GBP910C-26 Kit includes the GBP910C Powerunit and a 26-foot Hose Kit, part number 910705

The GBP910C-38 Kit includes the GBP910C Powerunit and a 38-foot Hose Kit, part number 910709

The GBP910C-52 Kit includes the GBP910C Powerunit and a 52-foot Hose Kit, part number 910714

WARRANTY

Seller warrants that all goods covered by this catalog will conform to applicable specifications and will replace, or repair, F.O.B. our plant, any goods providing defective from faulty workmanship, or material, for 90 days from date of shipment.

Said warranty to remain in effect if and only if such goods are used in accordance with all instructions as to maintenance, operation, and use set forth in manuals and instruction sheets furnished by seller.

Sellers obligation under this warranty shall be limited to the repair or rework of the goods supplied or replacement thereof, at Seller's option, and in no case is to exceed the invoice value of said goods. Under no circumstances will seller be liable for incidental or consequential damages or for damages incurred by the buyer or subsequent user in repairing or replacing defective goods or if the goods covered by this warranty are reworked or subjected to any type of additional processing.

This warranty is void if Seller is not notified in writing of any rejections or defects within 90 days after the receipt of the material by the customer.

THIS WARRANTY IS MADE IN LIEU OF ALL OTHER WARRANTIES, EXPRESS OR IMPLIED, INCLUDING MERCHANTABILITY.